





---

## **Cable Management System**

for DC WALLBOX 50 Electric Vehicle Charger

## **Installation instruction**

---

## Table of content

<b>1 Document management.....</b>	<b>5</b>
1.1 Change history .....	5
1.2 About this instruction manual.....	5
1.1 Safety instructions.....	5
1.2 Safety precautions.....	7
1.3 Recommended tools .....	8
<b>2 Product description .....</b>	<b>9</b>
<b>3 Package contents .....</b>	<b>11</b>
<b>4 CMS for DC WALLBOX 50 - installation procedure.....</b>	<b>12</b>
4.1 Final steps .....	16
<b>5 Maintenance .....</b>	<b>17</b>
<b>6 Spare parts.....</b>	<b>18</b>

# 1 Document management

## 1.1 Change history

Date	Document Version	Created	Approved	Changes
23.09.2025	00	JMi	JMi	Initial version

## 1.2 About this instruction manual

This document describes the procedure of cable management system (CMS) installation on the DC WALLBOX 50 electric vehicle charger.

### 1.1 Safety instructions

All safety instructions in this manual are based on the results of the risk assessment carried out in accordance with the Machinery Directive 2006/XX/EC Annex I and EN ISO 12100. Where applicable, the life cycle phases of the product were taken into account.

#### WARNING



#### Electric shock

Danger of electric shock or injury.

- Turn OFF power at the main distribution board before working inside the equipment or removing any component.
- Do not remove circuit protective devices or any other component until the power is turned OFF.
- Do not touch the electrical wires.

#### WARNING



#### Injury through suspended load or lifting equipment

Persons in the vicinity of the installation site immediately before the charger being installed can be injured by lifting equipment or suspended loads. Secure the installation site against unauthorised access.

### WARNING



#### Fire through overheating of terminals

Damaged or improperly connected terminals can cause electric sparks and overheating.

- Use contact paste
- Apply correct torques to terminals.
- If there are any signs of overheating, the charger must be shut down and repaired.

### WARNING



#### Electric shock

Risk of electric shock through incorrect identification of wires or wire colours.

- Follow instructions when connecting wires.

### WARNING



#### Electric shock

Risk of electric shock during measuring of voltage on uncovered leads.

- Wear electrician's gloves.

### WARNING



#### Electric shock

Risk of electric shock through insufficient grounding of local grid.

- Before starting work, ensure that the local grid is sufficiently grounded.

### WARNING



#### Electric shock from enclosure

Risk of electric shock from enclosure through insufficient grounding of enclosure and doors.

- Before starting work, ensure that the enclosure is sufficiently grounded.

### WARNING



#### Electromagnetic field

Electromagnetic fields can interfere with cardiac pacemakers.

- Wearers of pacemakers should not stand too close to the control panel and the RFID reader.
- They should not stay near the charging cabinet longer than necessary.

### WARNING



#### Eye damage from arc flash

Opening or closing a circuit breaker can cause an electric arc. The high-intensity light can damage the eyes.

- Do not look at a circuit breaker when it is opening or closing.

### CAUTION



#### Tripping over charging cable

Charging cables pose a trip hazard.

- Secure cables when they are not in use.
- Pay attention during charging.

### CAUTION



#### Electric-arc flash hazard

Risk of burns from sparks or an electric arc caused by phases being connected to the wrong terminals.

- Follow the labels printed on the devices.
- Pay attention.

### CAUTION



#### Electric shock

Risk of electric shock from meter.

- When working on the meter, wear electrician's gloves.

### CAUTION



#### Injuries through being struck by falling objects

Loose equipment or quickly deposited tools may fall and cause injury.

- Ensure that you have enough room to carry out your work.
- Put tools away securely.
- Keep the workplace tidy.

## 1.2 Safety precautions

The following safety precautions must be followed:

- Read the manual before installation or using the CMS.
- The CMS must be installed by a trained technician according to the safety instructions and work instructions in this manual.
- The DC WALLBOX 50 charger must be switched off before the CMS installation.
- Do not put tools, material or body parts into the electric vehicle connector.

- The DC WALLBOX 50 must be powered up after installation to avoid condensation within the housing.
- Any repair of the CMS must be conducted by Delta, authorized service partner or Delta trained personnel. Otherwise, the guarantee is void.
- To avoid damage by lightning, local regulations must be followed.

### **1.3 Recommended tools**

The following tools are recommended for the EV charger installation:

- Key for opening of EVC front door
- Wrench size 13 or adjustable wrench
- Allen key 6 or HEX 6 bit
- TORX T25 bit

## 2 Product description

Cable Management System (CMS) for DC WALLBOX 50 charger consists of two cable holder assemblies. The main goal of CMS is to give the relief to the client in usage of the heavy charging cables and to prevent of long charging cables laying on the ground. The benefit is the reduction of risks of cable damage, the lowering of probability of personal injury and the increase of the user experience. CMS is shown in the following figure:

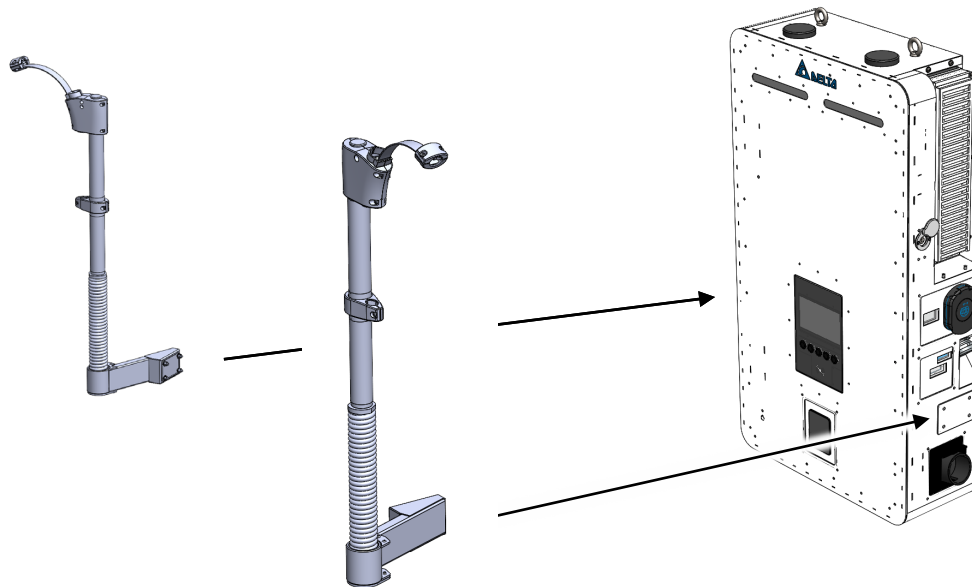

*Figure 1. Cable Management System (left and right assembly) to be mounted on the DC WALLBOX 50 charger*

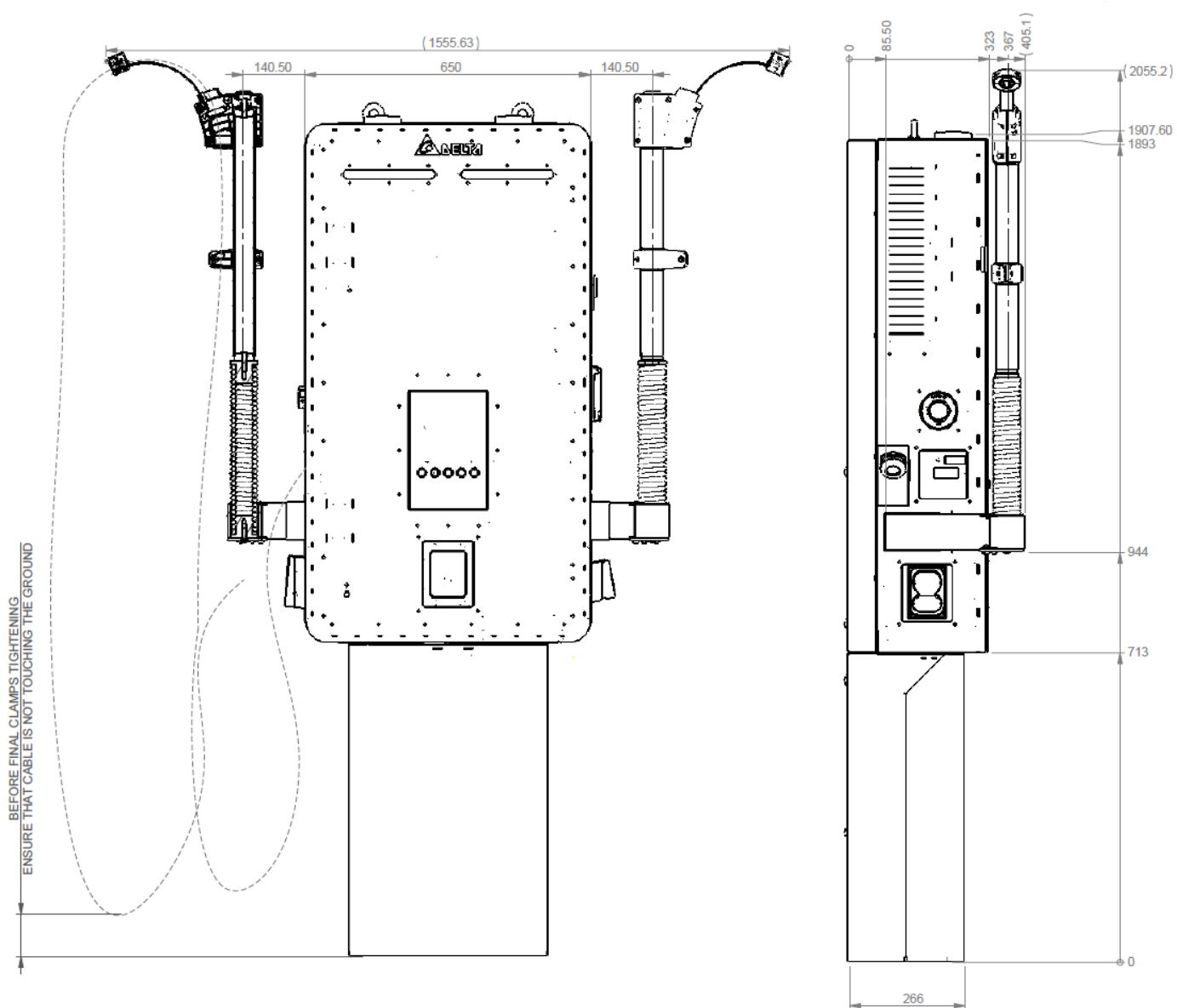

Figure 2. Drawing of CMS and DC WALLBOX 50

### 3 Package contents

The package containing items shown in table below:

PART NUMBER	DESCRIPTION	QTY
3798107679-S	CMS WB50 SPRING STD WITH PACKING	1 pc.

Table 4: Packing – item numbers and quantity.

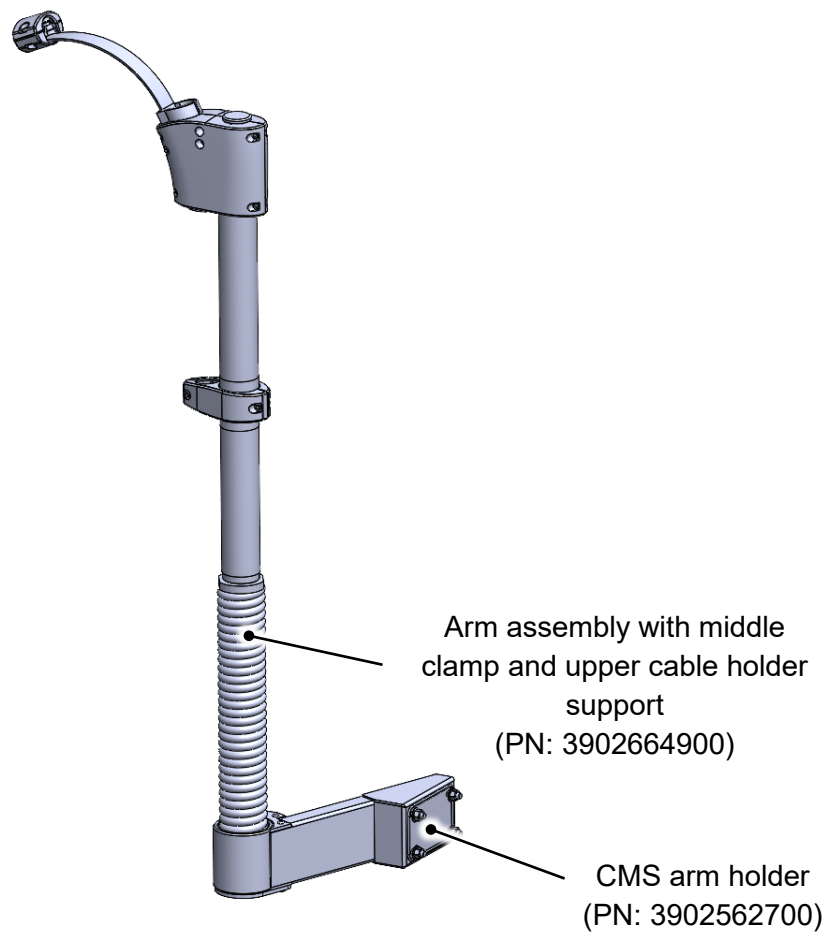
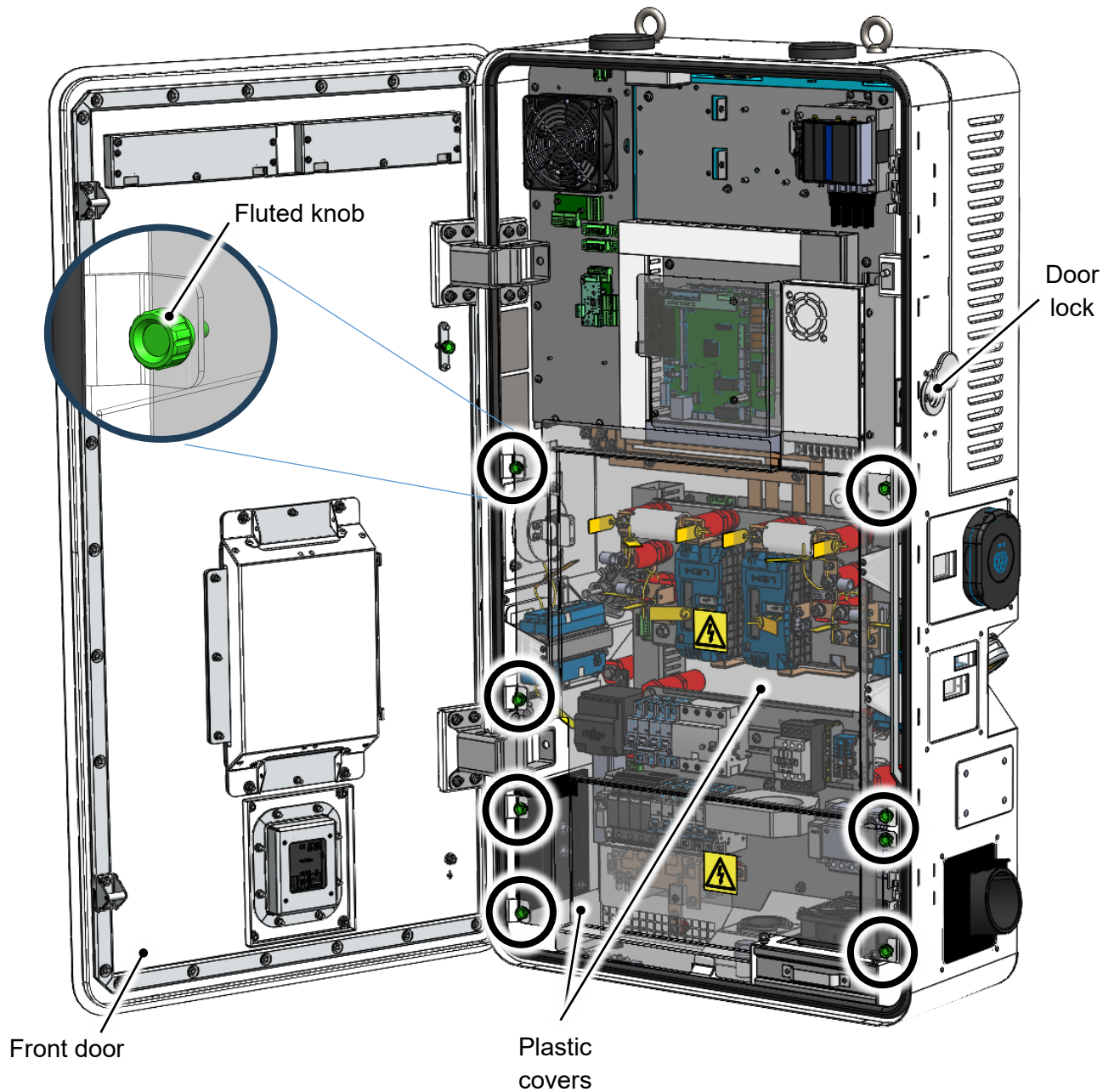

Figure 3. CMS DC50: Package contents

## 4 CMS for DC WALLBOX 50 - installation procedure

- Step 1 Unlock the front door and open it
- Step 2 Remove two plastic protection plates. Each one is held by four fluted knobs with male studs.



Step 3 Remove the blind cover on the left side. It is held in place by four M8 flange nuts.

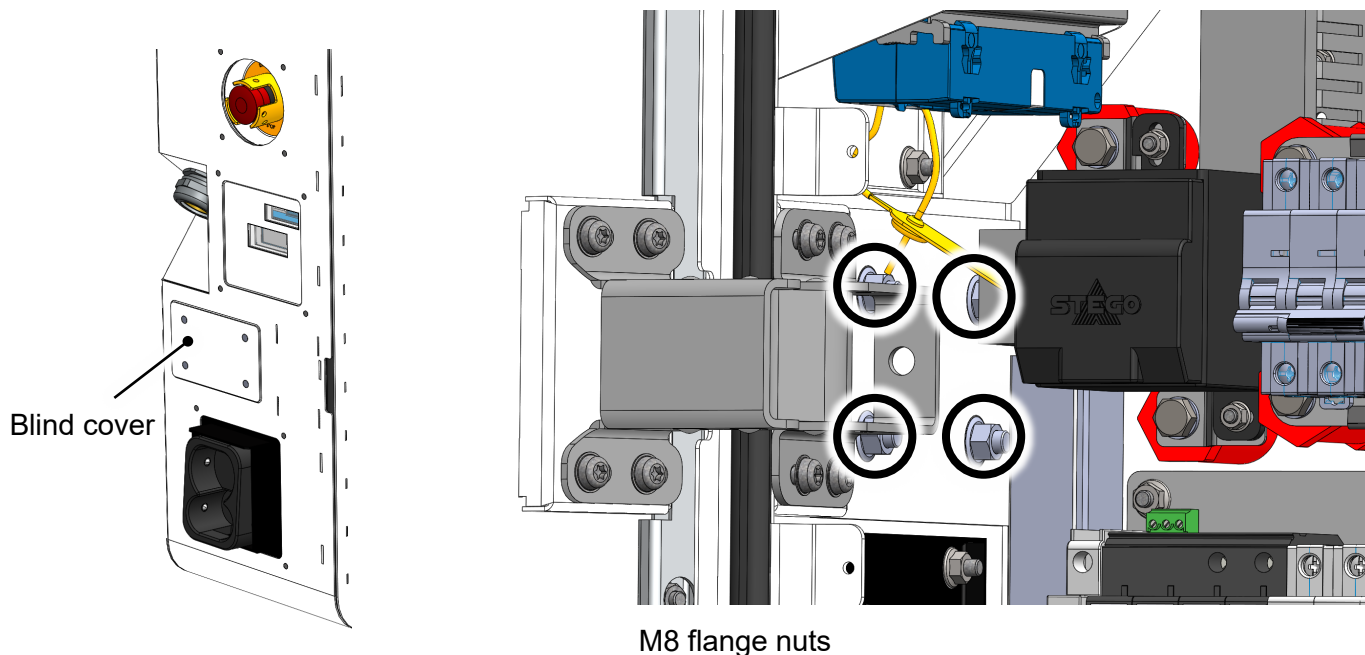

Step 4 Attach the left CMS arm holder to the DC Wallbox 50 using four M8 flange nuts.

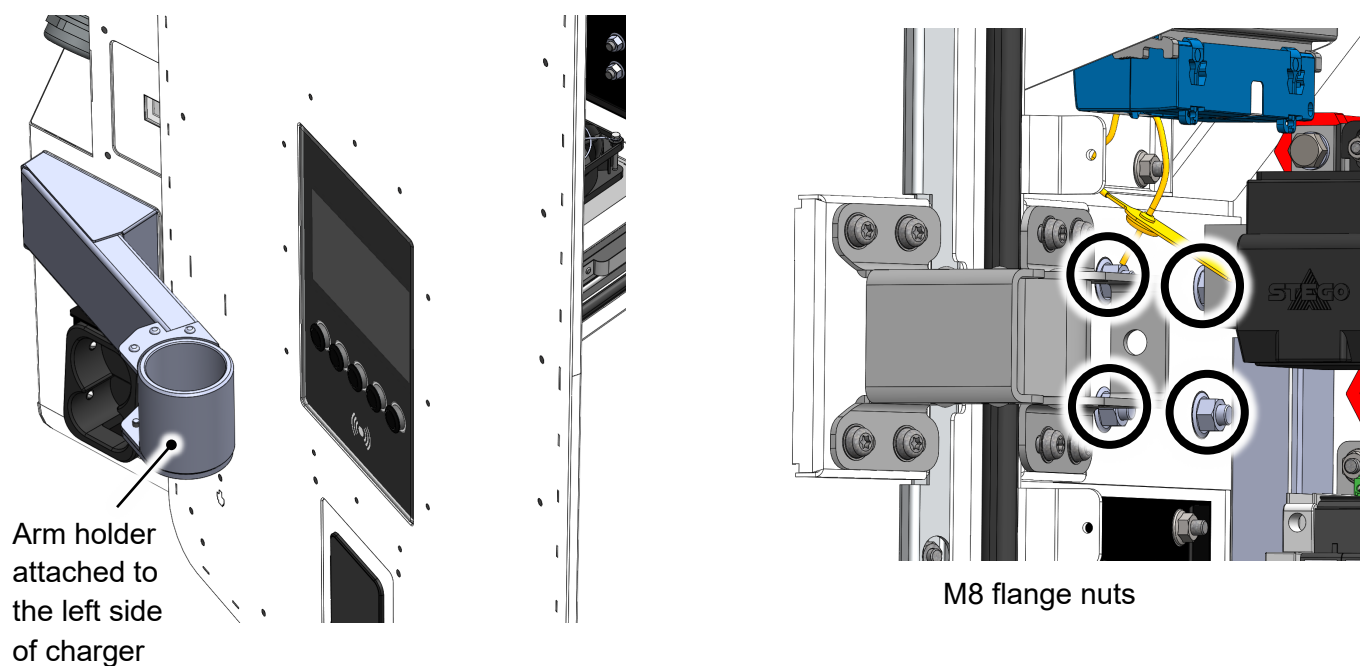

Step 5 Attach the left arm assembly to the arm holder using M10x30 flat head HEX screw. Tightening torque 46Nm +/- 5%.

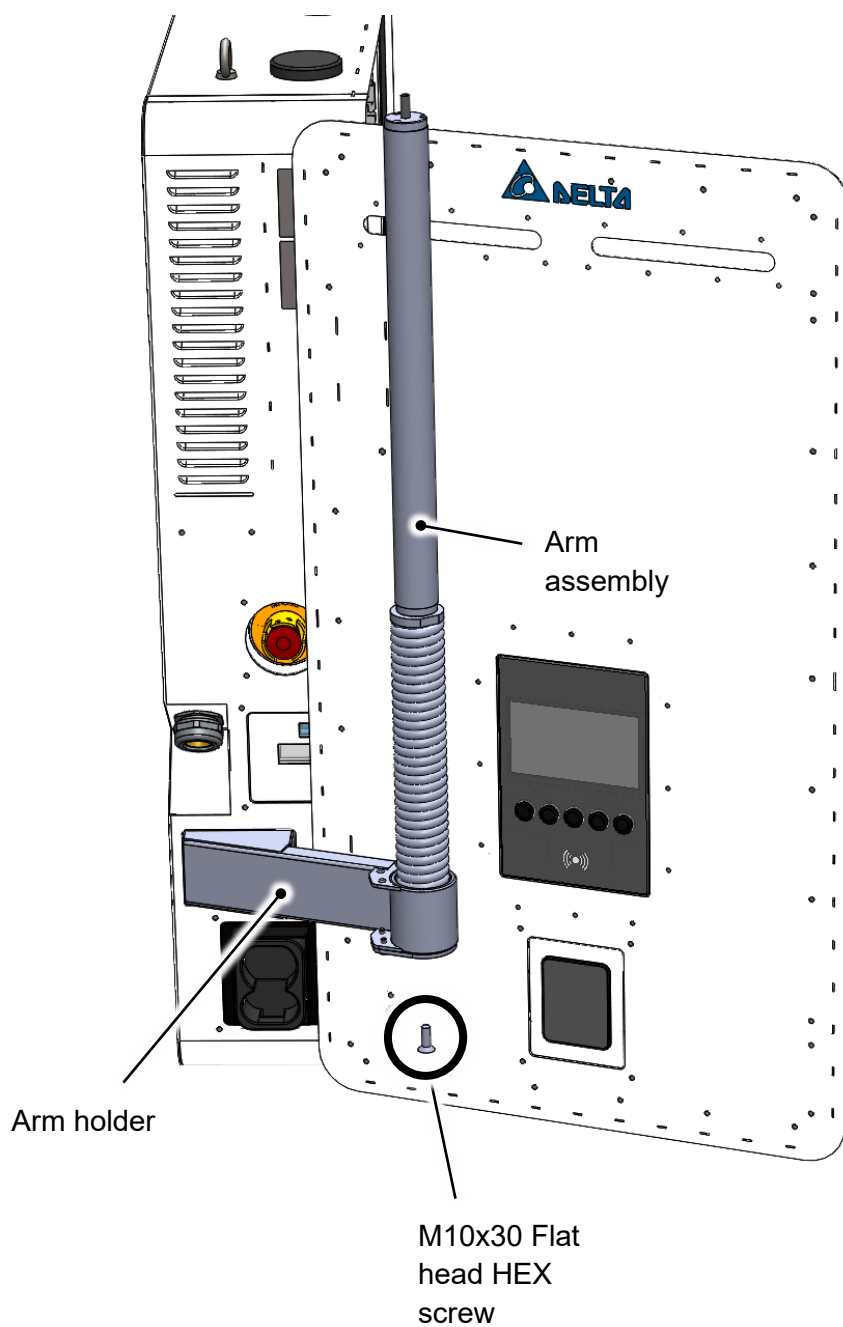

Step 6 Place the sliding bearing on top of the arm assembly and secure it in place with M10 self-locking nut. Unscrew seven M5x16 TORX screws from the cable holder support which is attached to the charging cable from the factory and place its one half to the arm assembly as is shown in the figure below.

Connect both halves of the cable holder support using seven M5x16 TORX screws.

Cover the hole with the plug.

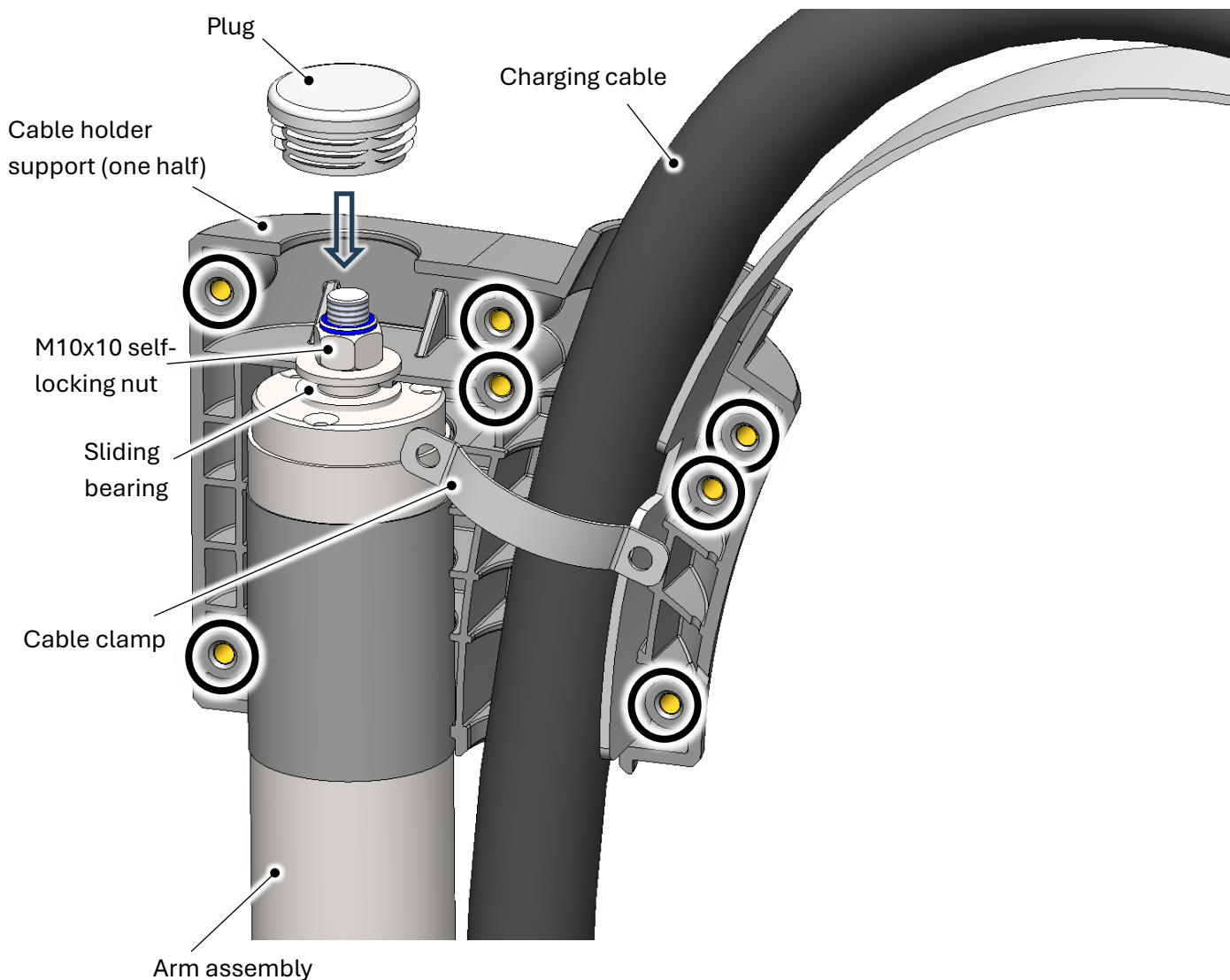

- Step 7 Optionally, install the middle cable clamp to the cable holder. The middle clamp holder consists of two segments connected by two (M5x20 TORX) screws. Figure below shows installation principle and correct placement of the middle clamp holder as well as the charging cable routing.

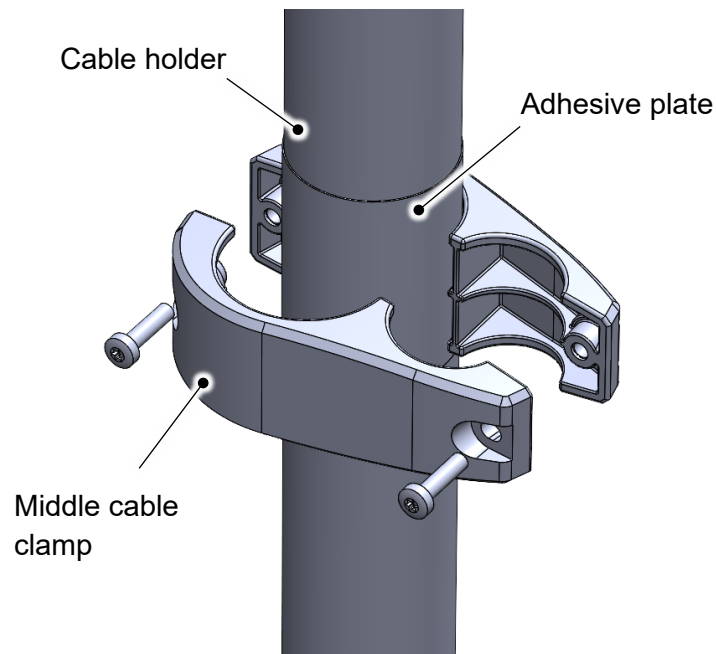

- Step 8 Repeat the installation process for the right-side CMS.

#### 4.1 Final steps

- Step 1 After the CMS installation is finished, check the functionality of both cable holders. They must allow the charging cables to move freely. The springs of both holders must always return to initial position after the manipulation with the charging cable.
- Step 2 Clean the whole area, throw away the packaging material.

## 5 Maintenance

Cable management system for the DC Wallbox 50 is supposed to be maintenance-free. Maintenance per se is therefore reduced to replacing damaged parts and subassemblies.

During the regular charger maintenance, visually check the CMS on both sides:

- plastic parts (for signs of cracking),
- steel parts – for paint, scratches, signs of rust,
- screws - if they are not loosened nor damaged,
- spring - if it keeps original shape (no buckling / bending without external force) and if it is not loosened from spring fixation parts (risk it could suddenly fall-out),
- cables - if insulation is not damaged, not broken / bent with too small radius, not touching ground and if properly fixed in clamps.

If found damaged elements, order spare parts and replace it. Tight loosened screws /parts.

## 6 Spare parts





3484328400	HOLDER CMS UNIVERSAL SUS	
3484328800	PLATE BOTTOM COVER SUS 98.5*73*5 PAINT	
3902539800	SPRING OD60 V4 ASSY	
3902540500	PIPE OD48 WITH PLUGS ASSY	
3902547400	CABLE CLAMP EVC PIPE48 CABLE32 ASSY	
3902546200	EVC CABLE HOLDER W SUPPORT ASSY	
3231173200	GROMMET PE 36*12 BLK	

Table 1: List of spare parts for DC Wallbox 50 CMS

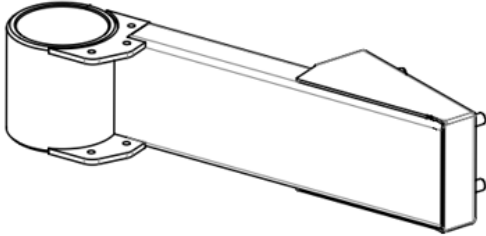
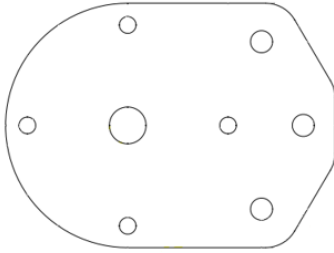
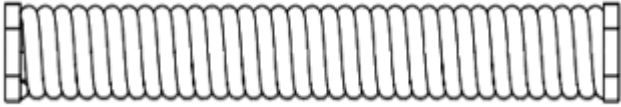

### **Delta Service Contacts**

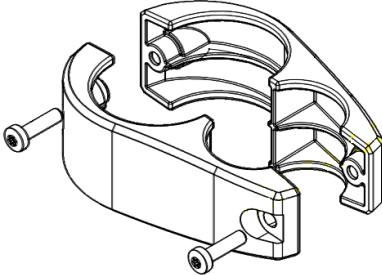
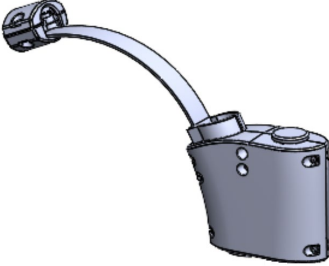
EVCS.Service@deltaww.com

Delta Electronics (Netherlands) BV  
Zandsteen 15, 2132 MZ Hoofddorp,

Tel.: +31 20 655-0900

[Evcs.emea@deltaww.com](mailto:Evcs.emea@deltaww.com)

[Emobility.delta-emea.com](http://Emobility.delta-emea.com)

### **About Delta**

Delta, founded in 1971, is a global leader in power and thermal management solutions. Our mission is “To provide innovative, clean and energy-efficient solutions for a better tomorrow,” and our businesses encompass Power Electronics, Energy Management, and Smart Green Life. Delta has sales offices, manufacturing facilities and R&D centers worldwide. In 2014, was ranked at the highest A-level of the Climate Performance Leadership Index of the Carbon Disclosure Project (CDP). Since 2011, Delta is part of the Dow Jones Sustainability Indices (DJSI) World Index.



5017711800\_00