

# 350KW Power Cabinet

## EU Service Manual



Delta Electronics, Inc.

Version: 1.0

# TABLE OF CONTENTS

<b>IMPORTANT SAFETY INSTRUCTIONS .....</b>	<b>4</b>
<b>IDENTIFY MODEL VARIANT .....</b>	<b>5</b>
1. SPECIFICATION LABEL .....	5
2. MODEL NAMING RULE .....	6
<b>FUNCTION SYSTEM DIAGRAM .....</b>	<b>7</b>
<b>COMPONENT PLACEMENT .....</b>	<b>8</b>
1. PREVENTIVE MAINTENANCE .....	15
2. PREVENTIVE MAINTENANCE PART REPLACEMENT .....	16
3. SPARE PARTS LIST .....	18
4. SPARE PARTS REPLACEMENT .....	20
<b>SUPPORT DOCUMENTS .....</b>	<b>26</b>
1. SERVICE CHECK LIST .....	26
2. RECOMMENDS TOOLS .....	26

## Copyright

The ownership and all intellectual property rights of this power cabinet troubleshooting manual (this “Manual”), including but not limited to the content, data and figures contained herein are vested by Delta Electronics, Inc. (“Delta”). The Manual can only be applied to operation or use of the product. Any disposition, duplication, dissemination, reproduction, modification, translation, extraction or any other usage to the Manual is prohibited without obtaining Delta’s prior written permission. As the product will be developed and improved continuously, Delta may modify or update the Manual from time to time without any notice. Delta will do its best efforts to keep the Manual updated and maintain the accuracy of the Manual. Delta disclaims any kinds or forms of warranty, guarantee or undertaking, either expressly or implicitly, including but not limited to the completeness, accuracy, non-infringement, merchantability or fitness for particular purpose or usage.

Copyright © Delta Electronics, Inc. All Rights Reserved.

## IMPORTANT SAFETY INSTRUCTIONS

- This document provides instructions for the Delta 200KW-350KW power cabinet and should not be used for any other product. Before installation or use of this product, you should review this manual carefully and consult with a licensed contractor, licensed electrician or trained installation expert to make sure of compliance with local building codes and safety standards.
- Power cabinet should be installed only by a qualified technician.
- Do not use the Delta charger if the cabinet, power cord are frayed, have broken insulation or show any other signs of damage.
- Make sure that the materials used and the installation procedures follow local building codes and safety standards.
- The information provided in this manual in no way exempts the user of responsibility to follow all applicable codes or safety standards.
- The manufacturer is not responsible for physical injury, damage to property or damage to equipment caused by the installation of this device.



### GROUNDING INSTRUCTIONS



Always connect the Neutral at the service to Earth Ground. If ground is not provided by the electrical service, a grounding stake must be installed nearby. The grounding stake must be connected to the ground bar in the main breaker panel, and the Neutral must be connected to Ground at that point.

## IDENTIFY MODEL VARIANT

Delta power cabinet series comprises several model variants. A product sticker with the specific Delta product identification number is located on the left side of the power cabinet. Please check the product sticker to ensure that the model variant you have installed is the one described in this manual.

### 1. Specification label

- 350kW IEC System Specification Label

 <b>DELTA ELECTRONICS, INC.</b> <hr/> ELECTRIC VEHICLE CHARGING POWER CABINET USE WITH DISPENSOR FOR ELECTRIC VEHICLES. RAINPROOF IP55. INDOOR/OUTDOOR USE. MODEL NO.: EIDN-E350KTAXX INPUT: 3P+PE, 380-415Vac, 565A, 50/60Hz OUTPUT: 150 - 950Vdc, 540A+540A Max., 175kW+175kW. or 540A Max., 350kW. MAXIMUM OUTPUT : 350kW. AMBIENT TEMPERATURE: 60°C Max., 50°C-60°C de-rating DATE CODE: YYMM REV.: XX S/N: PPPYYWWSSSSSXX   DELTA ELECTRONICS, INC. MADE IN XXXXX	<p>Refer to the model naming rule</p> <p>XX:</p> <p>First X: Code for Manufacture (A:Chunli / B:Tainan / C:Dongguan / D:Deltagreentech / W:Wujiang)</p> <p>Last X: Code for Model Status(P: Prototype / E:EVT / D: DVT / 0: MP)</p> <p>PPPPYYWWSSSSSXX</p> <p>PPP: Code for Product ID</p> <p>YY: Code for Year</p> <p>WW: Code for Week</p> <p>SSSSS: Code for S/N:00001~99999</p> <p>XXXXX: Manufacturing location. For example: Taiwan, China., For example: Taiwan, WJ, China.</p>
---	--

## 2. Model naming rule

**E I D X - X X X X X X X X**

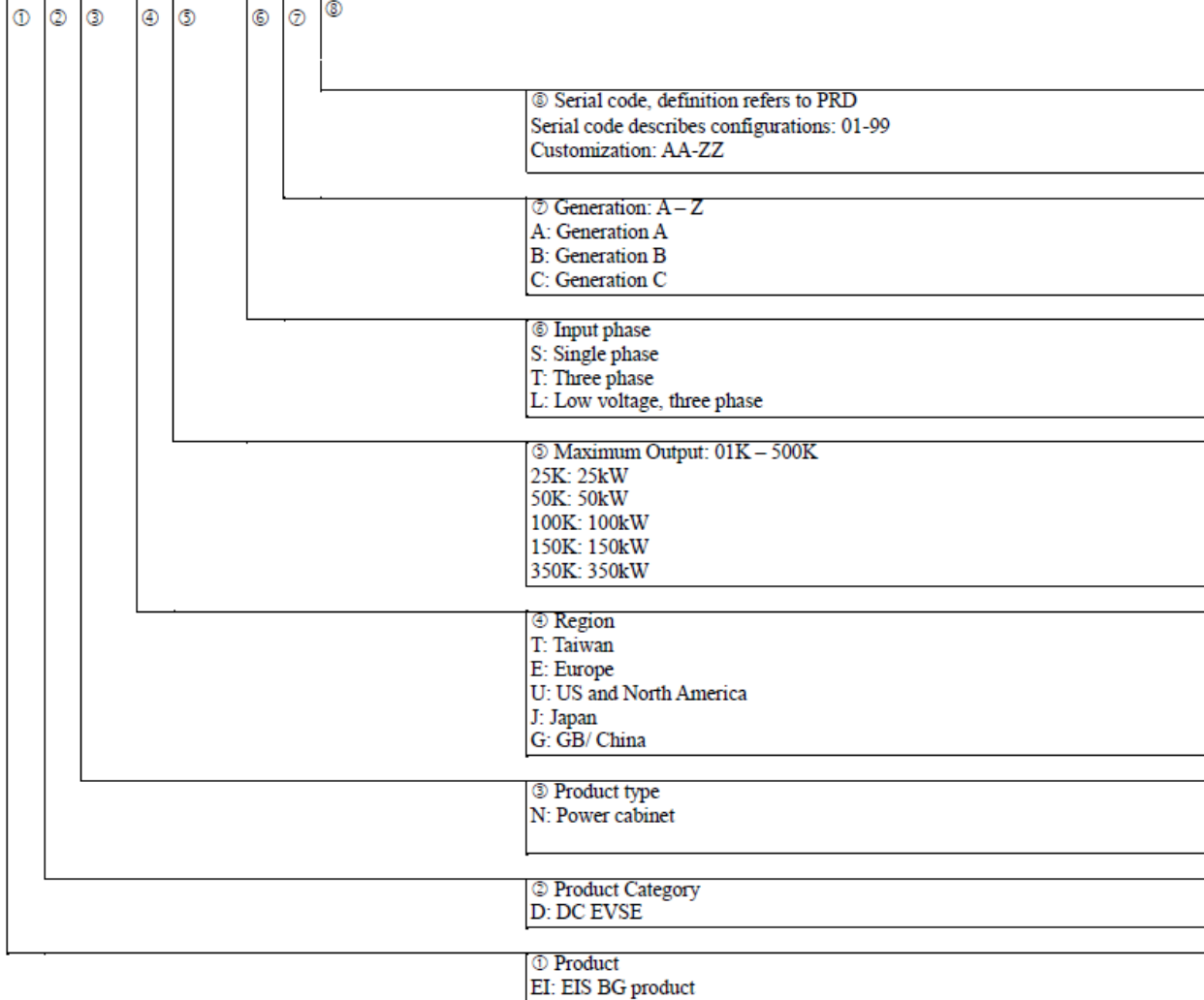

# FUNCTION SYSTEM DIAGRAM

- EIDN-EXXXXTXXX

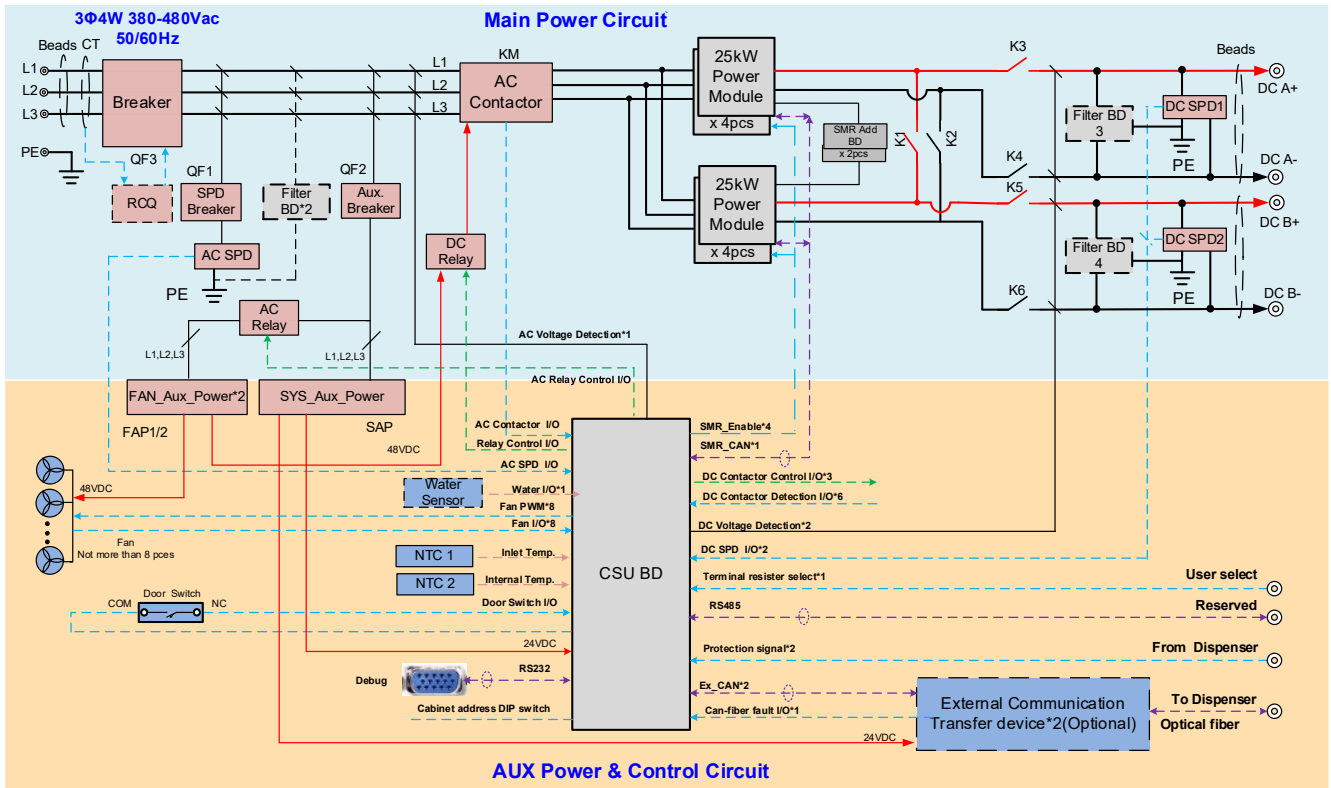

## COMPONENT PLACEMENT

1 · Open the front door (Internal of the cabinet):

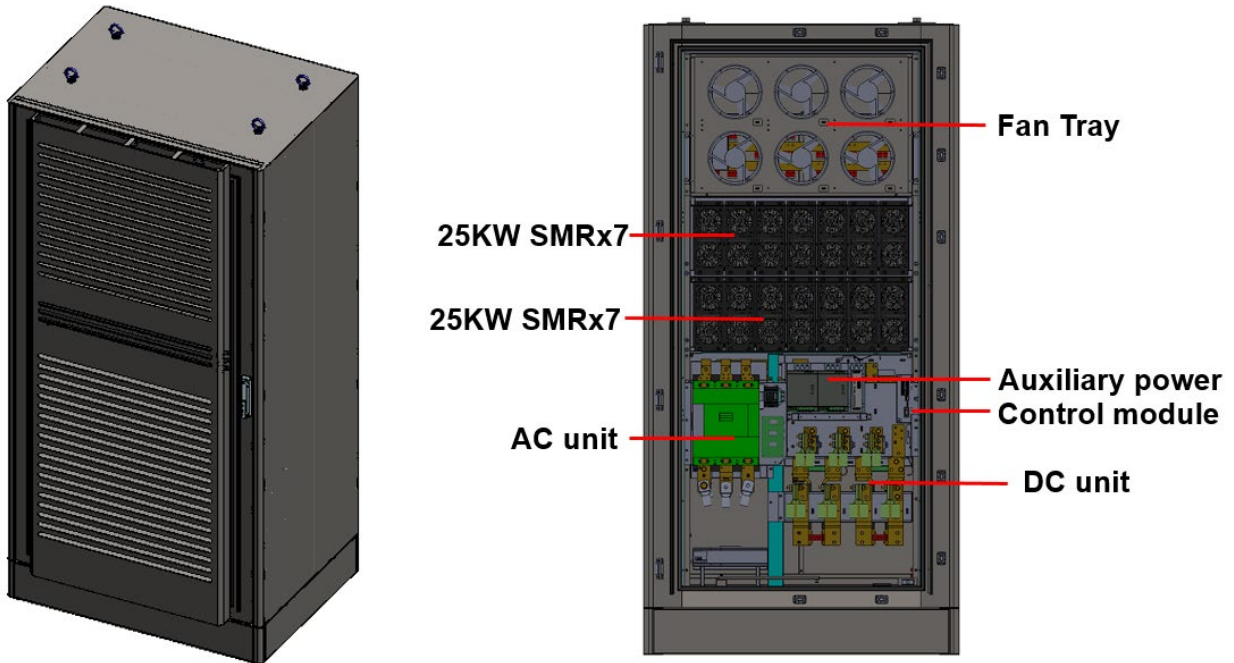

### AUX power breaker and AC SPD:

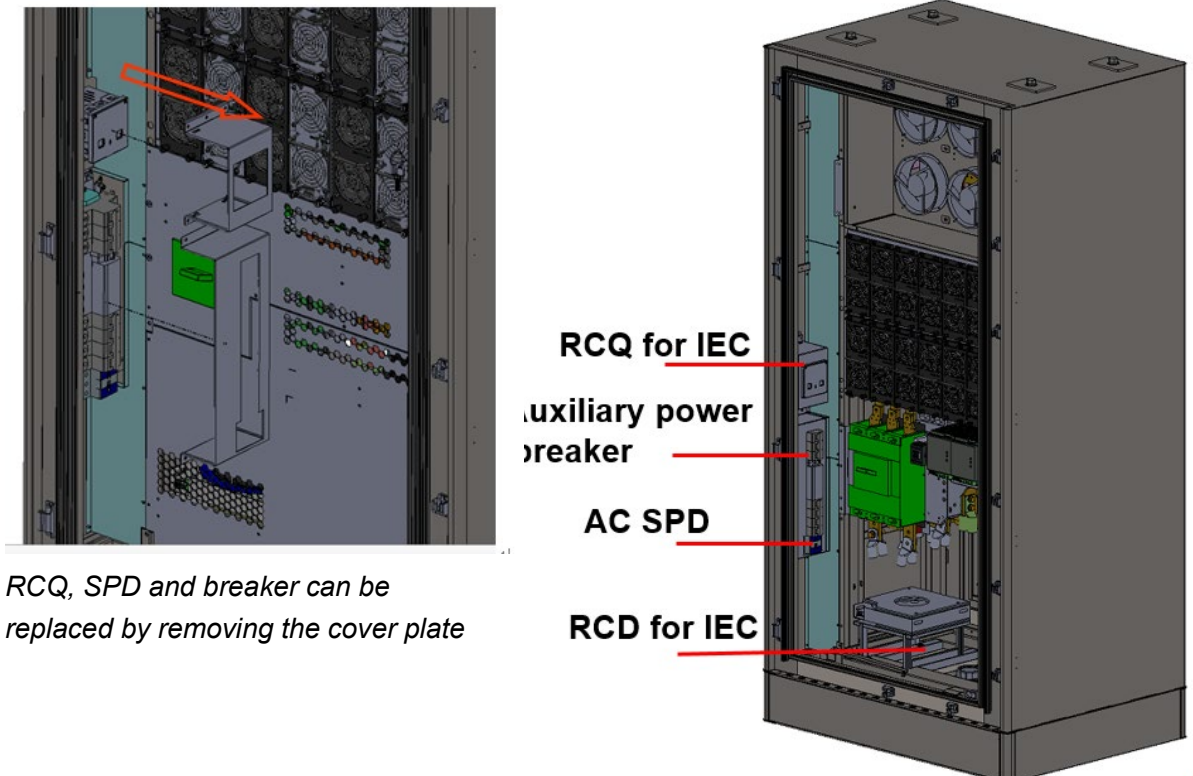

*RCQ, SPD and breaker can be replaced by removing the cover plate*

**DC SPD**

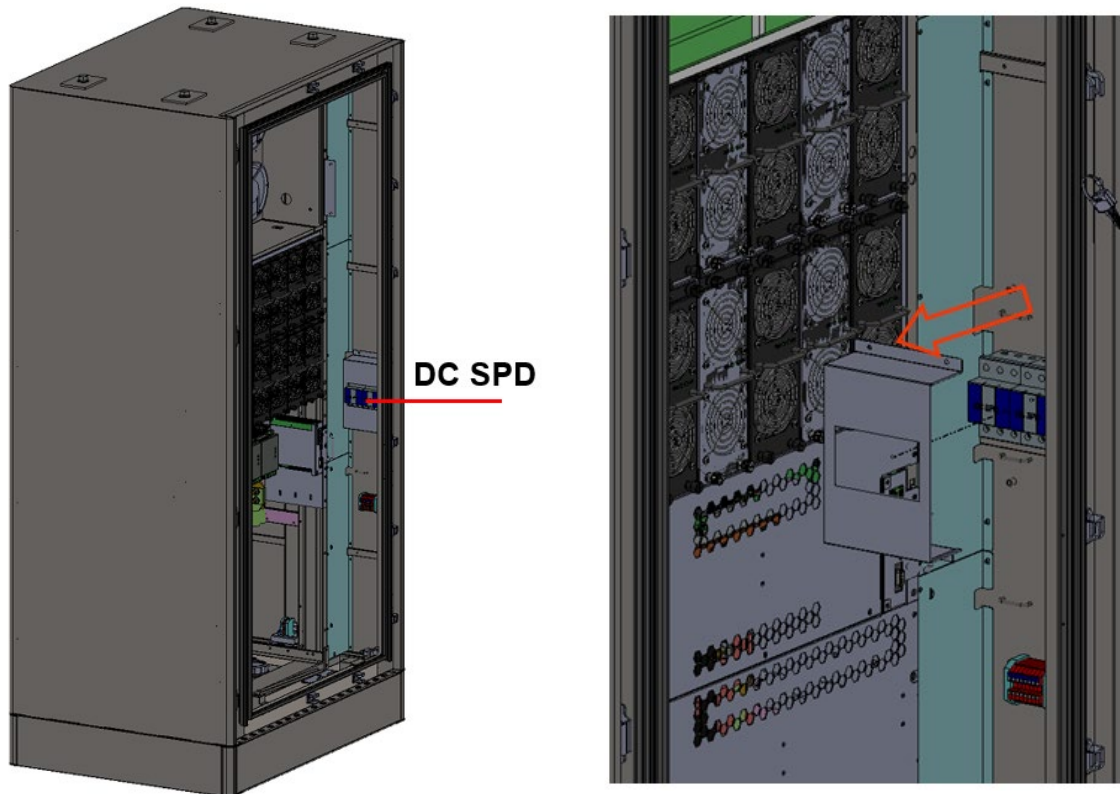

*DC SPD can be replaced by removing the cover plate*

**DC Connection Unit:**

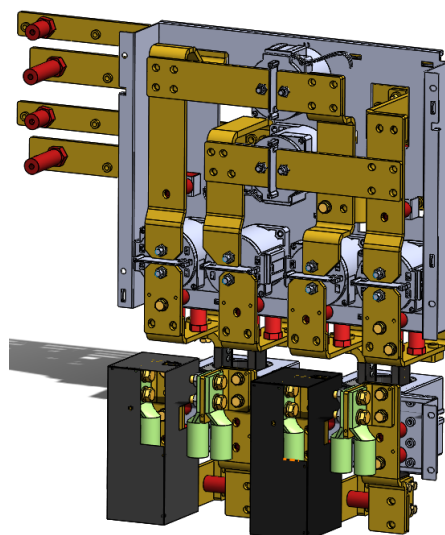

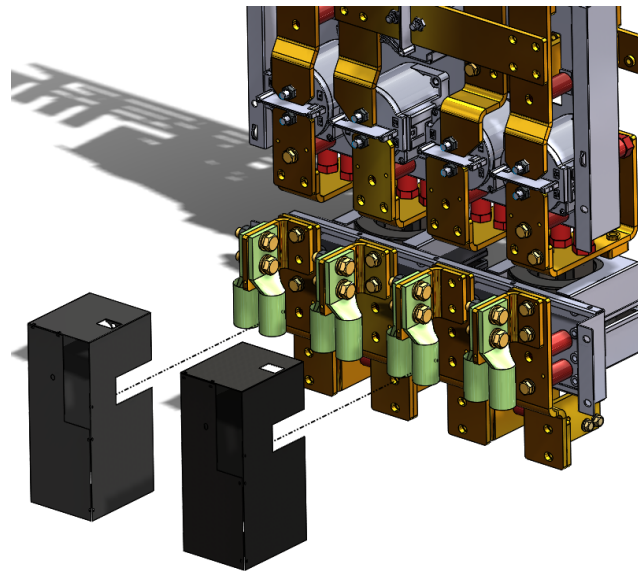
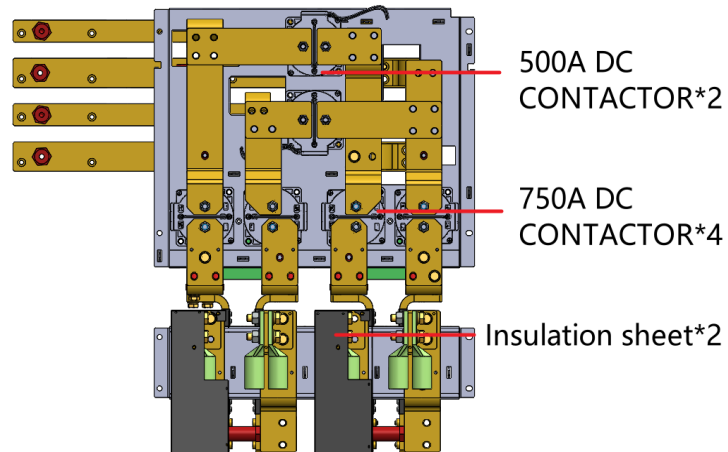

*Remove the insulating sheet before DC wiring*

**AC Connection Unit:**

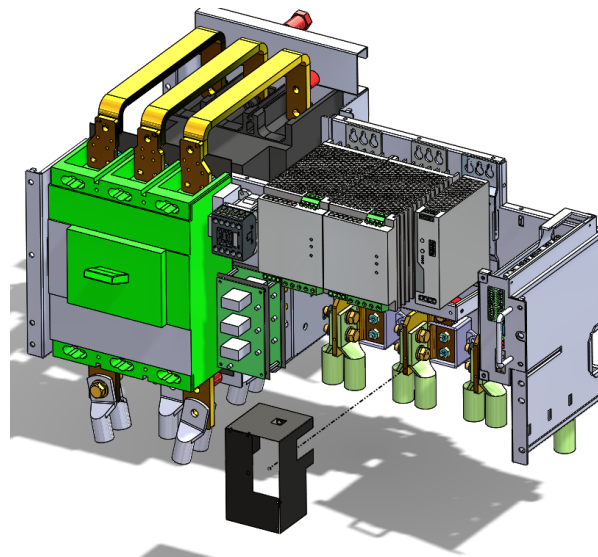
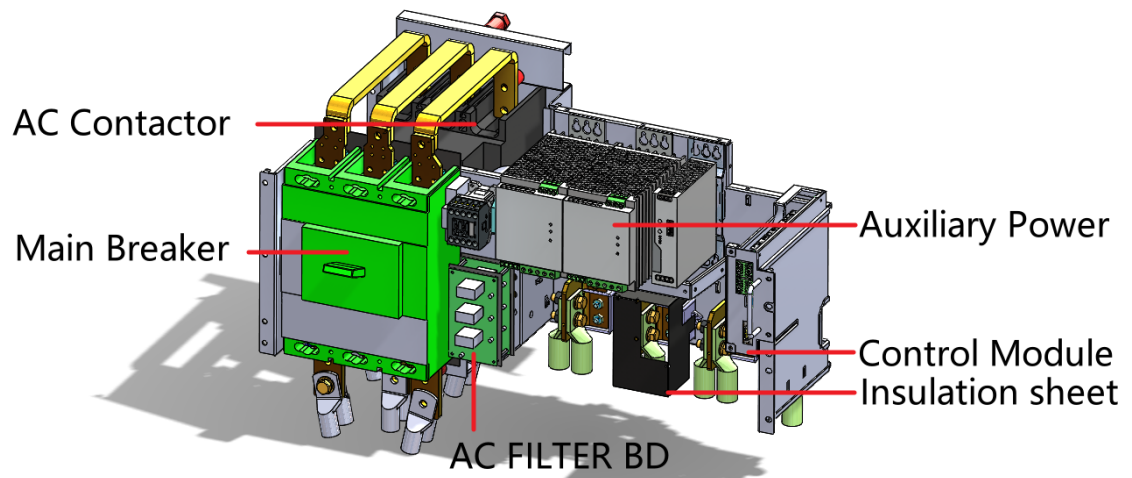

Remove the insulating sheet before AC wiring

*Notes: AC Filter board is optional.*

**Wire Routing Layout:**

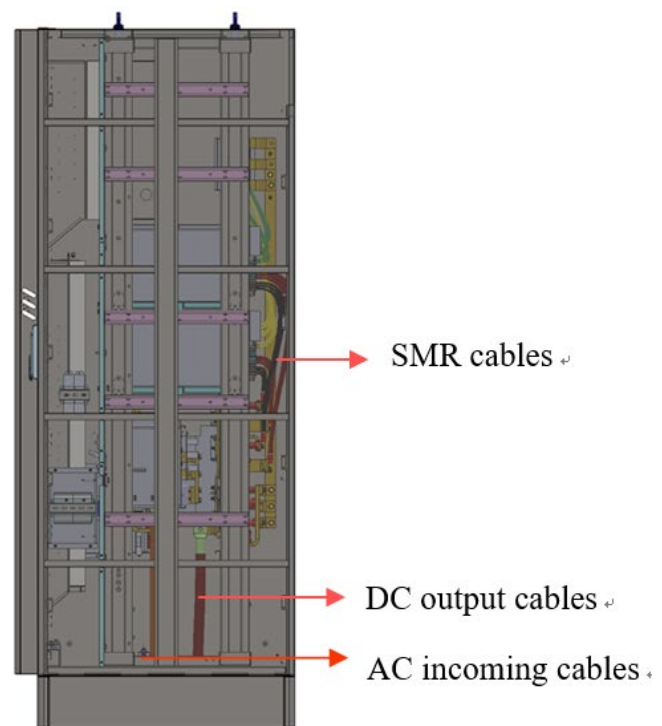

Facing the front door, the Rightside of the cabinet.

Notes: SMR- AC/DC power module

**Air filter and inlet air temperature sensor(NTC):**

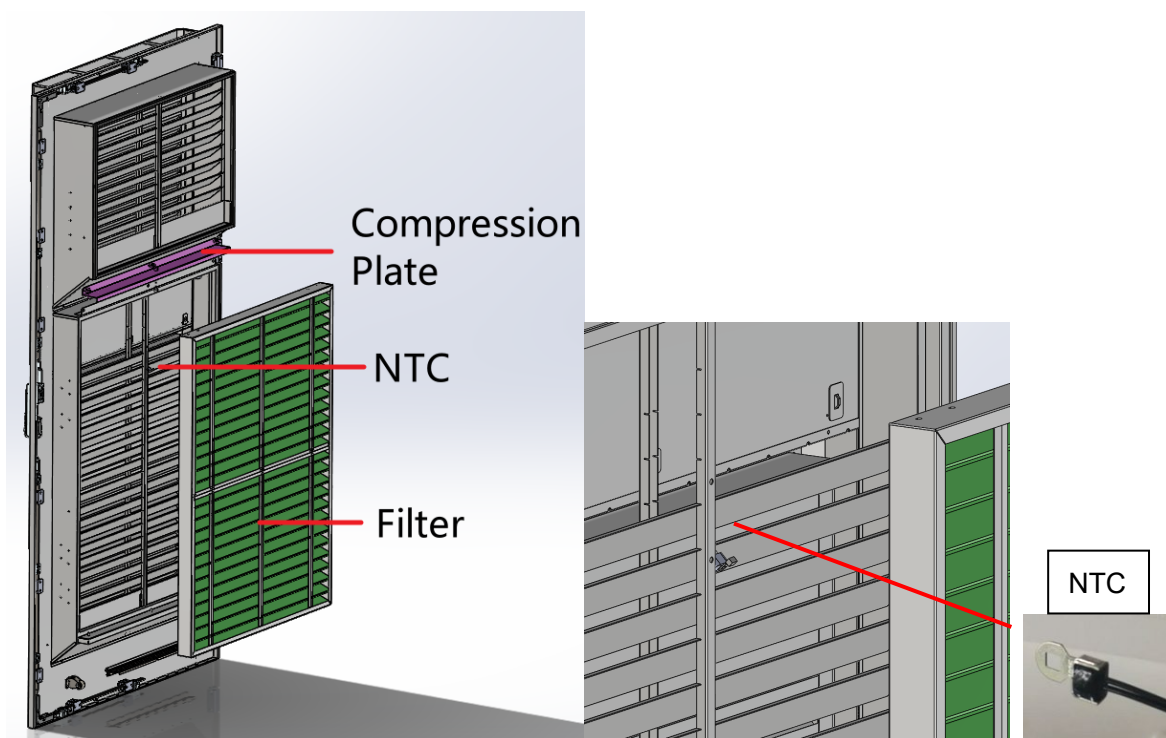

2、 Remove the back door(Internal of the cabinet):

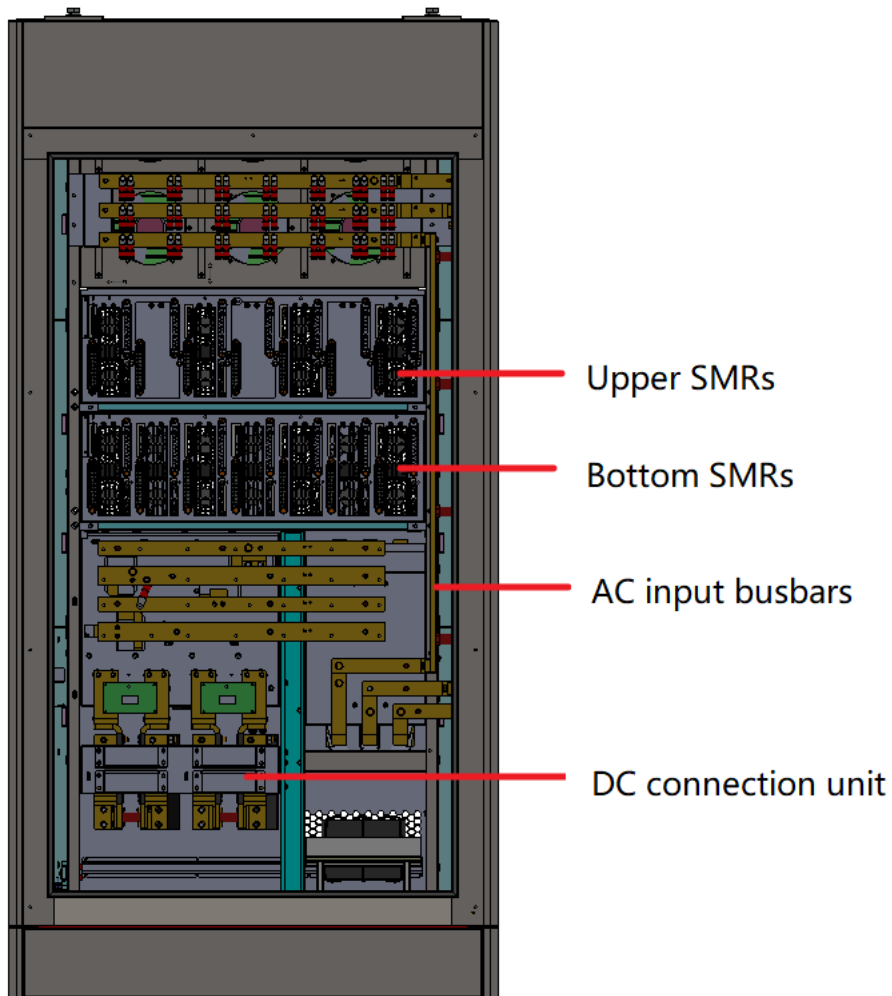

Wire Routing:

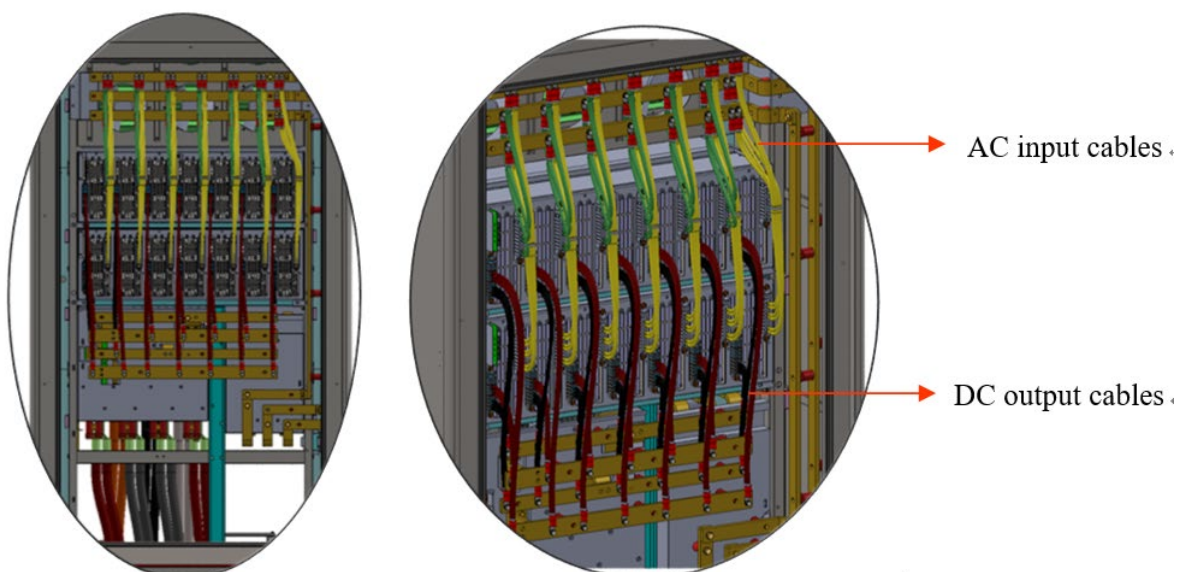

**AD-1-BD、AD-2-BD、DC filter BD**

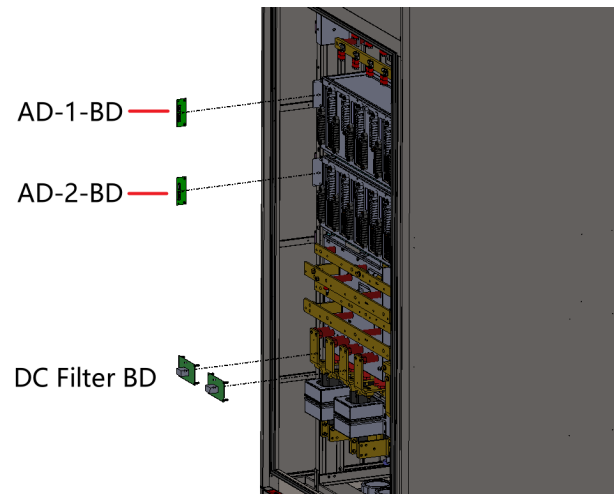

**Air outlet temperature sensor(NTC)**

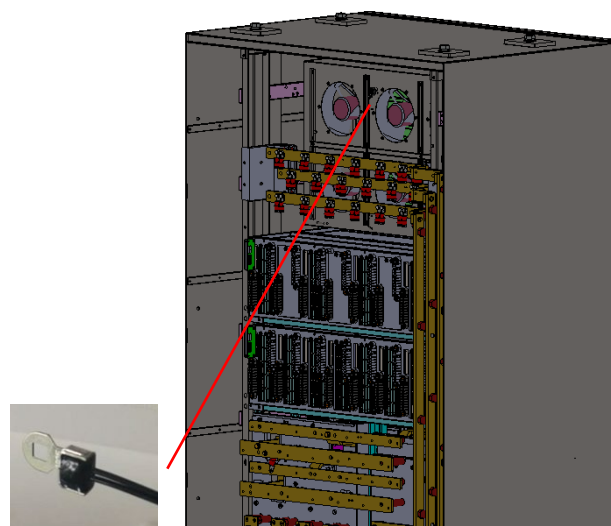

## MAINTENANCE INSTRUCTION

### 1. Preventive maintenance

It is recommended to conduct periodical inspection and maintenance to 350KW power cabinet. Below table shows the recommended preventive maintenance plan to ensure the power cabinet functionality and optimize the operation. The maintenance work is subject to operating condition of the charger. The spare parts in the preventive maintenance plan are not considered as parts failure. The supply and purchase of the spare parts included in the preventive maintenance plan shall be described in the Standard Warranty terms.

Note:

Filter and SPD are considered as consumables and are excluded in the Standard Warranty terms.

Components maintenance schedule												
Year Component		Yesrs from start up										
		0	1	2	3	4	5	6	7	8	9	10
0	Start-up / Commissioning	P										
1	Air filters		R	R	R	R	R	R	R	R	R	R
2	Power module 1-14		I	I	I	I	R	I	I	I	I	R
3	CSU module		I	I	I	R	I	I	I	R	I	I
4	DC SPD		I	I	I	I	R	I	I	I	I	R
5	AC SPD		I	I	I	I	R	I	I	I	I	R
6	AUX Power 960/120W		I	I	I	I	R	I	I	I	I	R
Procedure:												
Inspection (Visual inspection)												I
Performing on-site work (Commissioning, tests, measurements or other activities)												P
Replacement of component (Depending on the operation condition)												R

Recommended replacing period for components		
Component	Recommended replacement period	Estimated replacement time
Air filters	Replace each year, depending on the operating environment	Replacement:10 minutes
Power module 1-14	Replace in 5 years	Replacement:10 minutes
CSU module	Replace in 4 years	Replacement:10 minutes
AC SPD	Replace in 5 years	Replacement:30 minutes
DC SPD	Replace in 5 years	Replacement:30 minutes
AUX Power 960/120W	Replace in 5 years	Replacement:30 minutes
Listed periods are based on average use of charging point, replacement times are typical and may vary depending on site.		

## 2. Preventive maintenance part replacement



Safety Precautions: Always use appropriate Personal Protective Equipment while working on the chargers. These include:

- Electrical Hazard rated work boots.
- Arc Flash rated cotton Pants or Jeans.
- Arc Flash rated cotton Shirt.
- Work Gloves
- Hard Hat
- Safety Glasses
- Reflective or Day-glow vest



Warning: Power down the dispenser and power cabinet from the switch gear before conducting any replacement or installation. Non-compliance to this step may result to death or severe injury

### ▪ 2-1 Filter change instruction

Tools need:

- Phillip screwdriver

Step :

- 1) Open the front door
- 2) Remove the M6 screw x4pcs on the fan filter.
- 3) Remove the filter cotton in the direction of the arrow as shown in the figure

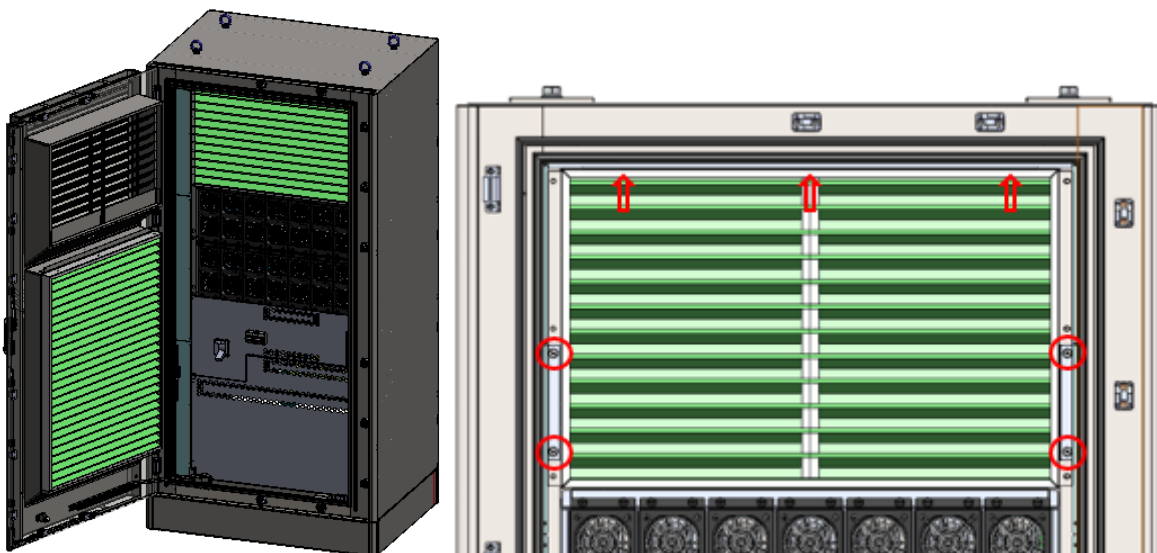

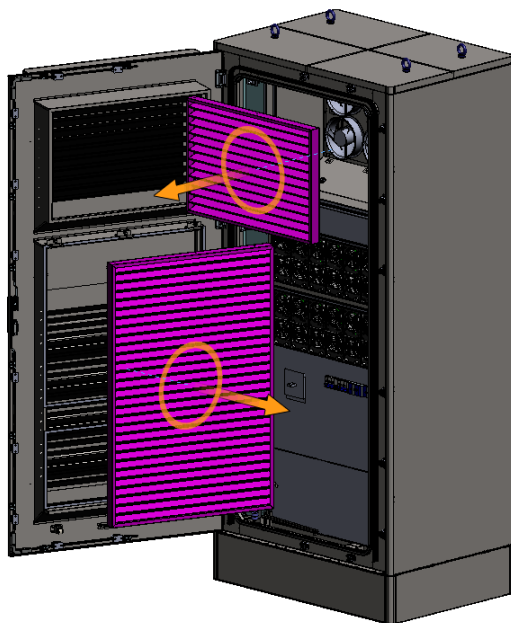
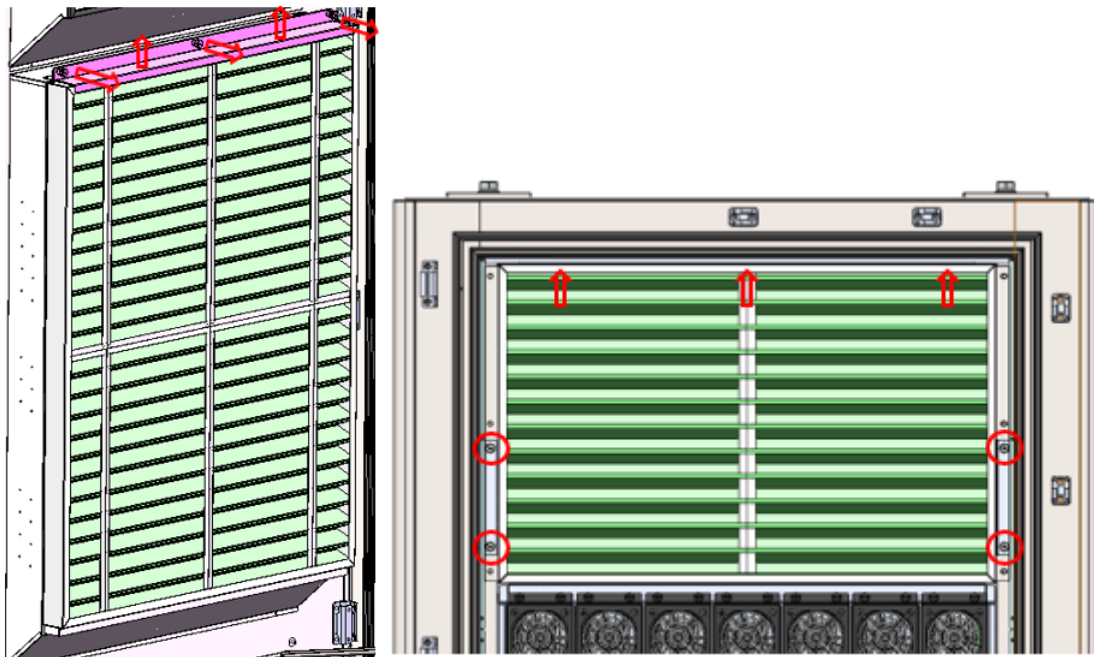

The filter screen is hung into the groove

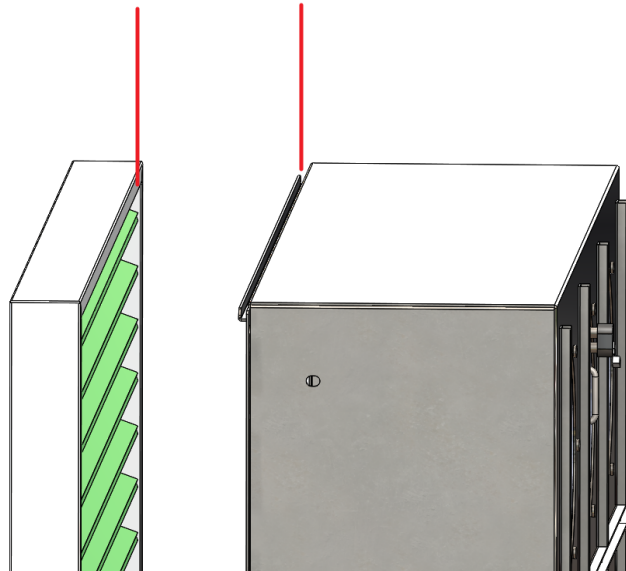

Note: when installing the upper end filter screen, pay attention to hang the upper part filter on the groove of the cabinet.

### 3. Spare parts list

Title	Delta P/N	Q P A	Service Level	Estimated replacement time (mins)	Remarks
Door lock-standard	3486054300-S	1	-	90	
Lock cover	3475423900-S	3	-	90	
Front door inside Gasket	3247472300-S	1		90	
Front door outside Gasket	3247472400-S	1		90	
Back door Gasket	3247472500-S	1		90	
F5 Filter(up)	3472130200-S	1	A	10	
F5 Filter(botton)	3472130300-S	1	A	10	
AC Main breaker	3798104923	1		120	
AC Contactor	0729116951	1		120	
AC SPD	0923811S72-S	1	B	30	
DC SPD	0921020872-S	2	B	30	
AC Breaker (For SPD)	0831717528-S	1		60	
3-Phase Filter BD	5501900728-S	2		90	
AUX. Power Breaker	3798105177	1		90	
AC relay	0729072451-S	1		90	
RCQ+TA	0839963028-S	1		90	
Power module 1~14	EIPM-25KTC01-S	1 4	B	30	
Power module connector assemble AC(1-7)	3082409901	7		90	
Power module connector assemble AC(8-14)	3082410001	7		90	
Power module connector assemble DC(1-7)	3082409701	7		90	

Power module connector assemble DC(8-14)	3082409801	7		90	
PWB ASSEMBLY AD_1_BD	5501900701-S	1		90	
PWB ASSEMBLY AD_2_BD	5501900700-S	1		90	
DC contactor 750A	0720002694-S	4		120	
DC contactor 500A	0721620794-S	2		120	
DC_FT_BD	5501900729-S	2		90	
CSU	5501900699-S	1		90	
Air inlet temperature detection/Internal temperature detection	091103WL16-S	6		90	
RES NTC	3070989694-S	3		120	
AUX.Power 960W (for fan, AC DC CONTACTOR COIL)	4900360834-S	2		60	Second source: Phoenix
AUX.Power 960W (for fan, AC DC CONTACTOR COIL)	4900384132	2		60	Main source: Weidmuller
AUX.Power 120W (back-up for CSU)	4900360934-S	1		60	Main source: Phoenix
AUX.Power 120W (back-up for CSU)	TBD	1		60	Second source: Delta
Door switch	3000749954-S	1		90	
System cooling fan x6	3620171811	6		90	
Flood senser	0939004300-S	1		90	

---

PE BUSBAR	3482866200-S	1		30	
-----------	--------------	---	--	----	--

**Note: Service Level define**

*A: Periodically maintenance is required. Typically the maintenance, repair and replacement time can be completed in 5 - 10 minutes.*

*B: Typically the maintenance, repair and replacement time can be completed in 30 minutes.*

#### 4. Spare parts replacement

Before replacing any components on chargers please read and follow the safety precautions and warning information



Safety Precautions: Always use appropriate Personal Protective Equipment while working on the chargers. These include:

- Electrical Hazard rated work boots.
- Arc Flash rated cotton Pants or Jeans.
- Arc Flash rated cotton Shirt.
- Work Gloves
- Hard Hat
- Safety Glasses
- Reflective or Day-glow vest



Warning: Power down the dispenser and power cabinet from the switch gear before conducting any replacement or installation. Non-compliance to this step may result to death or severe injury

##### • 4-1 Power Module replacement

Tools needed:

- No.2 Phillips screwdriver

Steps:

- 1) Open the front door with key lock
- 2) Release modules screws, 4pcs screws for each power module.
- 3) Pull out power modules. **Be noted that the module is very heavy, must to hold it with two hands.**

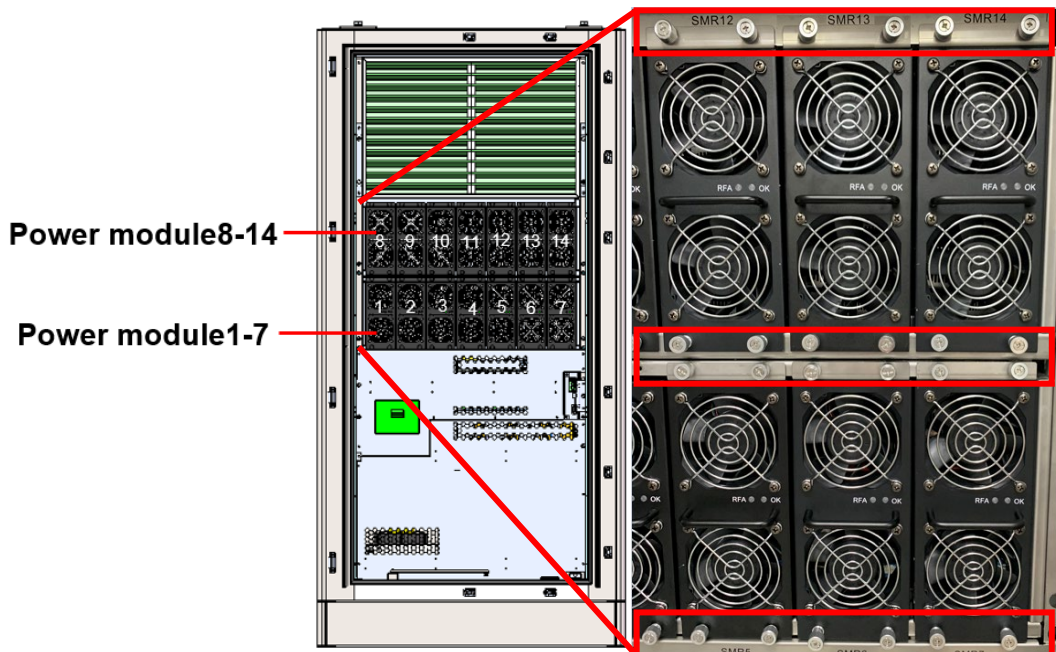

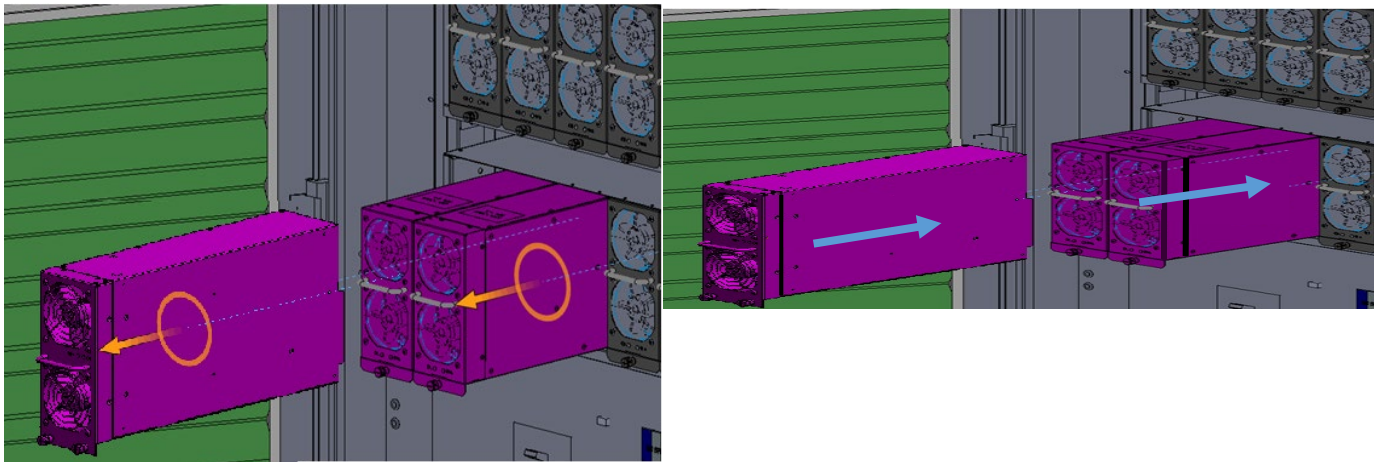

- 4) Carefully replace the power module and secure the screws
- 5) Close the left door and lock with key.
- 6) Connect the switchgear and power on the charger
- 7) Perform a charge session with both connectors

- **4-2 Replacement of 120W small power supply**

Tools needed:

- Screwdriver

Steps:

- 1) Loosen M5 screw the wiring on the small power supply:

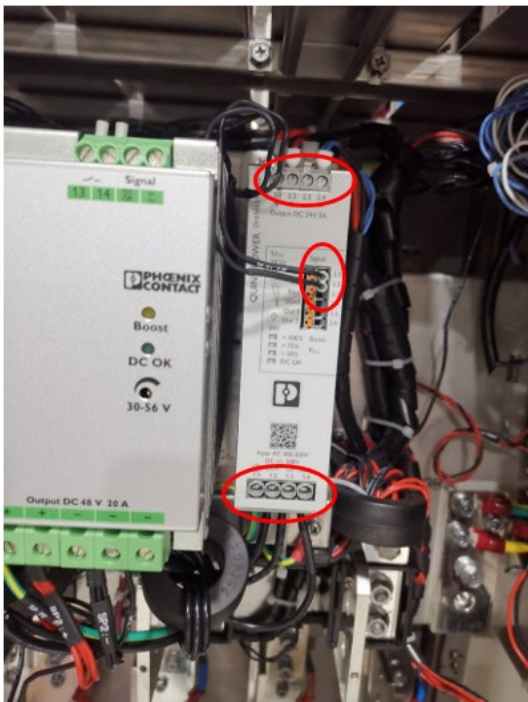

Warning: Take photos and remember the corresponding connection points of the small powersupply wiring marks to facilitate the final restoration of wiring

2) Loosen the locking screws between the small power supply backplane and the AC backplane (three at the top and three at the bottom, which can be loosened, not removed). The loosening degree can be easily removed by the small power supply (as shown in the figure below)

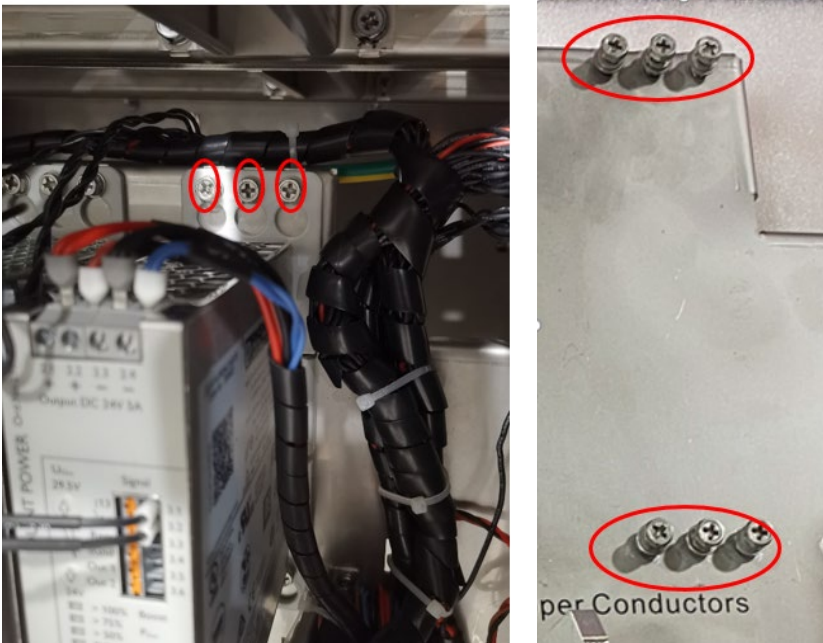

3) When the small power supply is lifted up and the screw is retracted to the large head area of the hoist mouth on the back plate of the small power supply, the small power supply can be removed from the vertical bottom plate



4) Remove the mounting screws of the back plate to replace the small power supply; Or, the small power supply with the backplane can be directly replaced according to the actual situation



5) Install the new power supply in the reverse order according to the disassembly order, and then connect the wires according to the wiring sequence of the photographing to complete the replacement of the 120W power supply



外接线标		外接线标		外接线标		外接线标	
CNA10	SP3:13/DC	CNA1 CNA3	SP3+	CNA20	SP3+	KA1:1L1	
	SP3:14/OK		SP3-		SP3-	KA1:3L2	
	SP2:13		KA2 A1		OPT2:NC/Y7:1	KA1:5L3	
	SP2:14		KA2 A2		OPT1:NC/Y5:1	SP3:L1	
	SP1:13		OPT2:24+Y2:1		SP3:L2		
	SP1:14		OPT1:24+Y1:1		SP3:L3		
	G11		OPT1:24-Y3:1				
	G13		OPT2:24-Y4:1				
			OPT1:COM/Y6:1				
			OPT2:COM/Y8:1				

Connection point of small power supply (SP3)



Warning:

1. When installing the small power supply, if the big head of the hoist mouth of the small power supply back plate is inserted into the M5 \* 16 bolt of the AC bottom plate and the small power supply is slid down, the bolt cannot enter the small head of the hoist mouth, it can be solved by adjusting the height of the M5 \* 16 bolt from the AC bottom plate;
2. Since the distance between the lower part of the small power supply and the wiring beam under it is only about 5.5mm (the actual size will be a little larger), when disassembling the small power supply, use a screwdriver with a rod diameter of no more than 5.5mm to prevent the three screws under the back

## 5 Support Documents

### 5-1 Service check list

Service Checklist for 350kW Power Cabinet			
Customer / Site name			
Address / Country			
Model No. / Serial No.			
Use Environment		<input type="checkbox"/> Indoor <input type="checkbox"/> Outdoor <input type="checkbox"/> Outdoor, and with cover	
Installation Date			
Activation date			
Usage Frequency			
Check Items		Description	
1	Check of ingress protection and internal covers	<input type="checkbox"/> Yes <input type="checkbox"/> No	
2	Check the wiring of water sensor is connected well	<input type="checkbox"/> Yes <input type="checkbox"/> No	
3	Check contactor is connected well	<input type="checkbox"/> Yes <input type="checkbox"/> No	
4	Check the fan is working when charging	<input type="checkbox"/> Yes <input type="checkbox"/> No	
5	Check of power module unit 1-14 is normal by the LED indicator	<input type="checkbox"/> Yes <input type="checkbox"/> No	
6	Check wiring connection of CSU1 module is well	<input type="checkbox"/> Yes <input type="checkbox"/> No	
7	Check of Main /AUX. power breaker	<input type="checkbox"/> Yes <input type="checkbox"/> No	
8	Check of SPD status	<input type="checkbox"/> Yes <input type="checkbox"/> No	
9	Replacement of air filters	<input type="checkbox"/> Yes <input type="checkbox"/> No <input type="checkbox"/> NA	
10	Failure description in detail. (attached photo, if necessary)		
Signature		Date	

### 5-2 Recommends tools

The following tools are recommended for maintenance:

- (1x) Gloves for installation work, insulating gloves for commissioning test
- (1x) Wire cutters / strippers

- (1x) No.2 Philips screwdriver
- (1x) Hex wrench socket 7mm
- (1x) Hex wrench socket 10mm
- (1x) Hex wrench socket 13mm
- (1x) Hex wrench socket 17mm
- (1x) Gloves for installation work, insulating gloves for commissioning test
- (1x) Voltmeter or digital multi-meter
- (1x) Wire cutters / strippers
- (1x) Philips screwdriver
- (1x) 90o Hex wrench socket 17mm
- (1x) 90o Hex wrench socket 19mm
- (1x) Wrench 13mm
- (1x) Wrench 17mm
- (1x) Wrench 18mm
- (1x) Wrench 19mm
- (1x) Hydraulic Crimping plier